



Air Deck Gas Deck Ovens

Item: _____
 Quantity: _____
 Project: _____
 Approval: _____
 Date: _____

Air Deck Gas Deck Ovens

Models:

- G56PB G56PT G56PT/B



Model G56PT

Standard Features:

- Stainless Steel Front, Sides, Top, Back and Legs
- Porcelainized Control Panel
- Full Deck Width, Balanced Spring-Loaded Door
- Stainless Steel Perforated Deck
- Adjustable Legs
- Electronic Ignition
- Snap Action Thermostat (550° F Max.)
- Heat Control Damper System
- Forced Air Combustion Burner; 80,000 BTU
- Single Speed Fan with ¾ HP Motor
- 55.5"W x 35.75"D Deck Surface
- 63"W x 45"D Floor Space
- 53"W' x 7½"H Door Opening
- One Year Limited Parts and Labor Warranty (USA & Canada only)

Optional Features:

- Direct Connect Vent - No charge

AIR DECK

Specifications:

Unique energy delivery system driven by controlled hot air flow designed for high volume operation. Offers minimum preheat time; no recovery time; consistent selected temperatures; high quality production, and menu versatility. Available in natural or propane gas.



Model G56PT/B

Garland Commercial Ranges Ltd
 1177 Kamato Road,
 Mississauga, Ontario
 L4W 1X4 CANADA

General Inquires 1-905-624-0260
 USA Sales, Parts and Service 1-800-424-2411
 Canadian Sales 1-888-442-7526
 Canada or USA Parts/Service 1-800-427-6668



MODEL	INPUT (BTU)	DECK : In (mm)		PIZZA CAPACITY	MOTOR	Cu Ft	Ship WT. lb/Kg
		WIDTH	DEPTH				
G56PB	80,000	35.75(908)	55.5(1410)	(6) 18"	120V, 1PH, 60Hz 15 Amps (1 per deck)	95	1000 /455
G56PT	80,000	35.75(908)	55.5(1410)	(6) 18"		95	1000 /455
G56PT/B	160,000	2@35.75(908)	2 @55.5(1410)	(12) 18"		190	2000 /910

Gas input ratings shown here are for installations tip to 2,000 feet (610mm) above sea level.
BTU input ratings must be derated for high altitude installations.

MANIFOLD OPERATING PRESSURE		MINIMUM CLEARANCES				
		Installation to Combustible Wall			Entry	
Nat	Pro	Sides	Rear	Base	Crated	Uncrated
3.5" WC	10.0" WC	6" (152mm)	6" (152mm)	8" (203mm)	45" (1143mm)	35-1/2" (902mm)

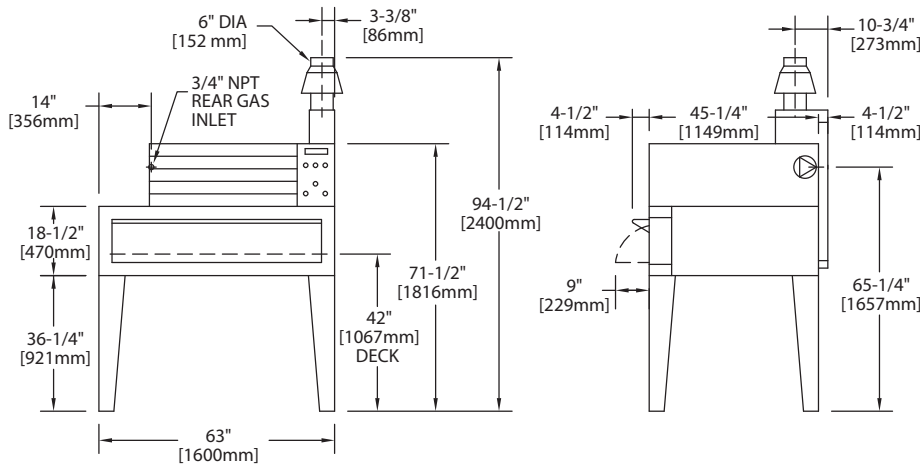

Deck with top power module and Direct Connect Venting

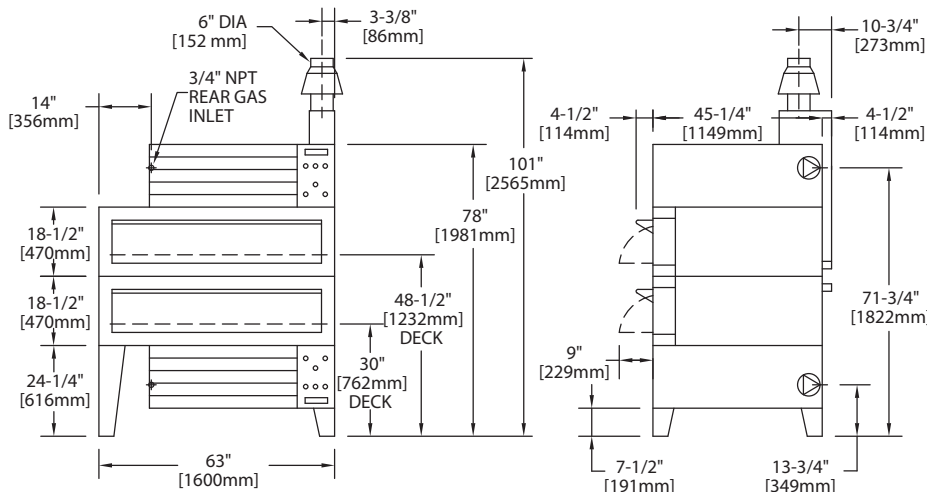

Deck (1) top power module (1) bottom power module and Direct Connect Venting

Form# G56 (05/03/13)